

Shoulder Studs No Thread

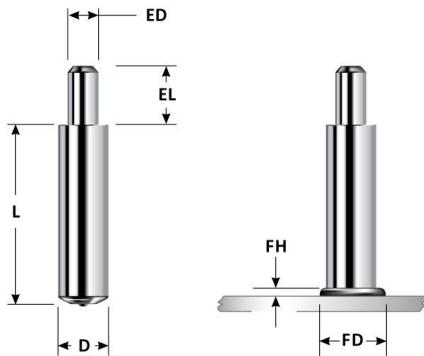

No Thread:

Base Diameter "D"	Minimum Length "L"	Extension Diameter "ED"	Extension Length* "EL"	Fillet Height* "FH"	Fillet Diameter* "FD"	Est. Burn* Off
.312	.500	.187	.250	.109	.437	.125
.375	.500	.187	.250	.125	.500	.125
.500	.625	.250	.250	.156	.625	.125
.625	.750	.250	.375	.187	.796	.187

* Approximate values
Other sizes available
Contact us if you have a special requirement

Material:

	Low Carbon Steel	Stainless Steel
Material:	ASTM A108 C1010-C1020 C-0.23% max; P-0.04% max MN-0.90% max; S-0.05% max	ASTM A276 302HQ/304/304L STANDARD 18-8
Mechanical Properties:	Min. Tensile Type A61,000 psi (420 Mpa) Min. Yield Type A49,000 psi (340 MPa) Min. Tensile Type B65,000 psi (450 MPa) Min. Yield Type B51,000 psi (340 MPa)	Other Grades Available Upon Request
Plating:	Available As Special Request	Plating Does Not Apply To Stainless Steel
Annealing:		Studs Are Annealed Where Required